

STANDARD OPERATING PROCEDURE FOR IN-PROCESS WELDING ON PIPELINES AND  
FACILITIES

By

Seth Loosli, B.A.

A Project Submitted in Partial Fulfillment of the Requirements

for the Degree of

MASTER OF SCIENCE

in

Project Management

University of Alaska Anchorage

December 2018

APPROVED

Roger Hull, PMP, Committee Chair  
LuAnn Piccard, M.S., Committee Member  
Raul Loya, Committee Member  
LuAnn Piccard, M.S., Chair  
Department of Project Management  
Robert Lang, Ph.D., Associate Dean  
College of Engineering



## Table of Contents

Title Page .....	<b>Error! Bookmark not defined.</b>
Table of Contents.....	3
List of Exhibits.....	4
Appendices.....	5
Abstract.....	6
Introduction.....	7
Explanation of In-Process Welding .....	8
Research.....	11
Research Method .....	11
Literature Review .....	12
Welding Procedure Specification .....	13
Procedure Qualification Record.....	13
Weld Cracking .....	17
Burn-through.....	20
In-Process Welding in the Field.....	21
Conclusions.....	22
Recommendations.....	22
References.....	23
Bibliography .....	<b>Error! Bookmark not defined.</b>

## List of Exhibits

Exhibit 1. Total cost of pipeline incidents in the state of Alaska 1998-2017 (PHMSA, 2018).....	7
Exhibit 2. Three common types of pipe damage (Reliable Pipes & Tubes LTD. 2018).	9
Exhibit 3. Artist depiction of Type B piping sleeve (Reliable Pipes & Tubes LTD. 2018).	9
Exhibit 4. Pipeline Incidents	10
Exhibit 5	16
Exhibit 6. This is an example of a test spool for welder qualifications on in-process systems (API 1999).	17
Exhibit 7. The temper bead process reduces the prevalence of crack-susceptible microstructures	18
Exhibit 8. Cracking most often occurs when the weld zone returns to ambient temperature (TWI, 1999).	19
Exhibit 9. Welding electrodes must be monitored to meet code and procedure standards	20
Exhibit 10. Weld coupons with different degrees of burn-through defect: (a) weld coupon No. 1; weld coupon No. 2; and (c) weld coupon No. 3. (NLM, 2018).	21

## **Appendices**

Appendix A. Standard Operating Procedure.....	25
Appendix B. Interviews .....	26
Appendix C. Field Welding .....	34

## **Abstract**

In-process welding has become a commonly used approach when installing upgrades or making repairs to piping systems that are live. Pipeline incidents occur every year, and they are often deadly and expensive. The research of this project set out to find out what components a standard operating procedure should have that would lead to reaching a zero percent incident rate while utilizing in-process welding to make money. Not every contractor has the internal processes formalized to perform this work safely in a high-quality manner. Successful execution of this work can lead to opportunities for contractors to expand their scope of operation and expertise further.

## Introduction

Construction began on the Trans-Alaska Pipeline System (TAPS) in 1974. A few short years later, oil was flowing from Alaska's northernmost shore down to the terminal in Valdez. Found along the length of the pipeline are varying environmental extremes (Brusso, 2018.). These corrosive environmental stresses coupled with erosion from flowing fluids can degrade a pipeline below safe levels in a matter of a few years. According to the National Energy Board of Canada, corrosion is the primary factor leading to the failure of oil and gas pipelines.

Pipeline incidents occur every year, and they are often deadly and expensive. According to the United States Department of Transportation Pipeline and Hazardous Materials Safety Administration (PHMSA), there have been 11,752 incidents, 331 fatalities, 1,292 injuries with a total cost of \$7,298,212,873 in damages from 1998 through 2017. During the same period in the State of Alaska alone, PHMSA recorded incidents have cost the state of Alaska a total of \$79,363,784. (See Exhibit 1.) (PHMSA, 2018).

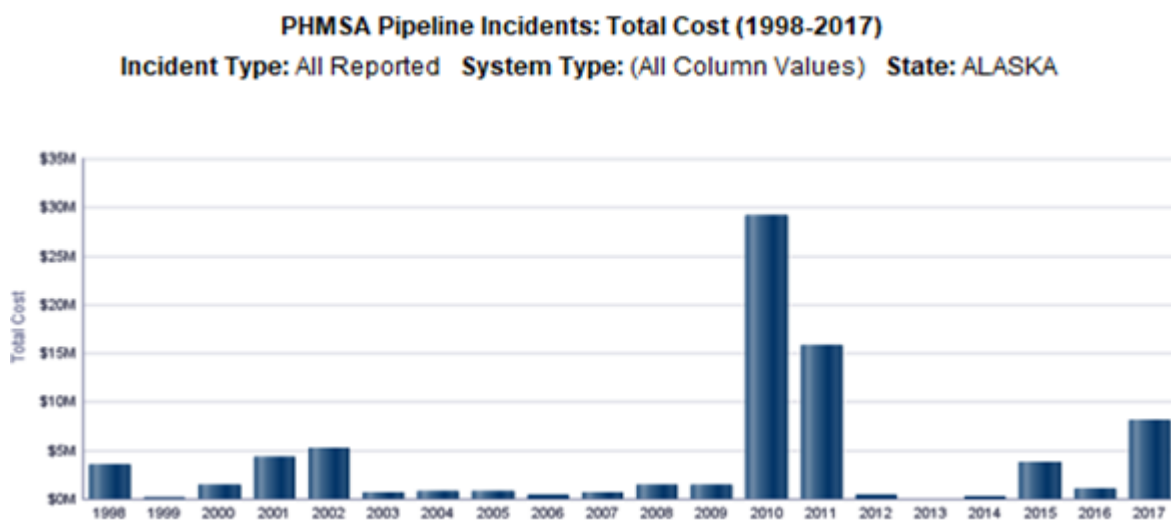

*Exhibit 1.* Total cost of pipeline incidents in the state of Alaska 1998-2017 (PHMSA, 2018).

PHMSA's record keeping shows how pipeline incidents can be costly for states with pipelines. Because in-process welding is a hazardous activity, it is of great importance that companies perform work without incident or injury to personnel, equipment, and the environment. Not all the above-listed incidents involved welding but, each incident that does occur near where welding is taking place is at risk for becoming a major disaster. Successful execution of this work can lead to opportunities for contractors to expand their scope of operation and expertise further.

In-process welding has become a commonly used approach when installing upgrades or making repairs to piping systems that are live. Furthermore, it is the preferred choice in procedure for pipelines and piping for the financial benefits. For contractors dealing with process piping, the opportunity to perform repairs on active or previously active piping systems is not always a reality. Not every contractor has the internal processes formalized to perform this work safely and profitability

The need for a standard operating procedure was identified by a group of welding supervisors that have been subcontracting this type of work. This project focused on combining academic research and field data to create a living document that will serve as a formalized checklist for in-process welding. Following a formalized guide for in-process welding can help a contractor perform work in a manner that is consistent with health, safety, and environmental requirements.

The modern construction approach applies scientific principles to project management by mapping and planning all project aspects, utilizing best-known methods. Part of project management duties includes expanding the customer base. Financial opportunities for a contractor with a developed an in-process welding plan are available. Right now, revenue is being lost by the in-process welding activities that get subcontracted to different companies that specialize in this type of work.

### **Explanation of In-Process Welding**

When piping system damaged is discovered by visual inspection, x-ray or other inspection types, repairs must be made to maintain the integrity of that system. In-process welding is used to repair piping systems that have damage but are still safe to operate. If the damage found poses an immediate risk to personnel, the environment, and assets that system is usually shut down as fast and safe as possible. Usually when this shutdown happens, if the product cannot get diverted, money is lost because the system must shutdown. The scenario mentioned above can be avoided in most cases if the appropriate inspection and repair schedules get followed.

Three main types of damage that can commonly occur on piping systems are erosion/corrosion, holes, and cracking (See Exhibit 2a.). Erosion is caused by moving fluids on the inside of piping systems. Although this damage is on the inside of piping, it can be fixed utilizing a sleeve repair method and an in-process welding procedure.

This project is examining in-process welding for the installation of metal sleeves (Type B) (See Exhibit 2b.) while excluding newer composite type sleeves (Type A). Type B sleeves will generally be made of two welded half pieces of pipe that encapsulate the damaged area on a live piping system. These halves are welded directly on to the live lines and then welded together. Once the sleeve repair welding is completed the space between the damaged pipe and the sleeve are filled with a specially made grout. This grout is used to increase the structural integrity of the damaged area.





*Exhibit 2.* Three common types of pipe damage (Reliable Pipes & Tubes LTD. 2018).

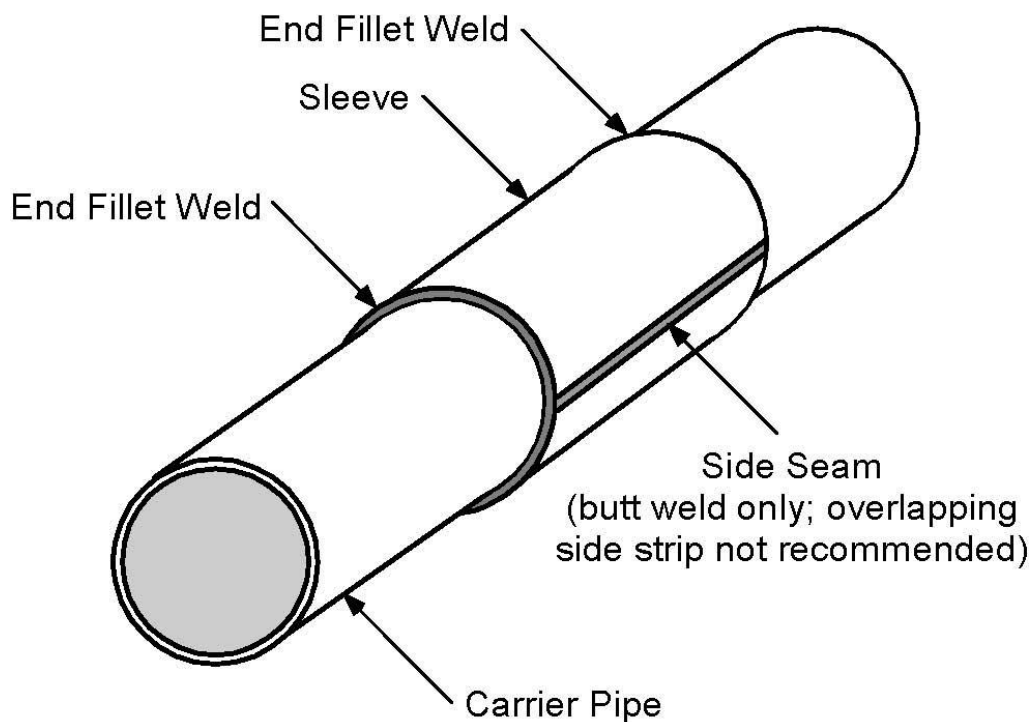

*Exhibit 3.* Artist depiction of Type B piping sleeve (Reliable Pipes & Tubes LTD. 2018).

The continuous flow of profitable product is a core deciding factor in choosing in-process welding for live repairs. Type B sleeves are usually cheaper, but they cannot be used in piping systems that have weight restrictions. Depending on the size of the damaged piping, Type B sleeve can exert too much weight stress.

A benefit of this type of repair is that the product flow can be decreased enough to make welding on the active process safe while the system can remain profitable. This process also reduces the need to utilize hazardous material procedures to clean existing piping. Hazardous material procedures are expensive and impractical especially on large sections of a pipeline.

The United States has roughly 2.5 million miles of pipeline, much of these systems contain liquids that are often harmful and deadly (Exhibit 3). Utilizing in-process welding procedures can help

mitigate the risk of exposing people and the environment to these hazards. While using in-process welding techniques, these hazards can be drastically reduced.



*Exhibit 4. Pipeline Incidents*

The above top left picture is from a natural gas pipeline explosion on Tuesday, Dec. 5, 2017, outside of Dixon, Illinois (Alex T. Paschal / AP). The top right photo is the aftermath of a December 11, 2012 explosion in West Virginia (National Transportation Safety Board). The bottom left is a picture of

rescuers in-front of an explosion in Central Mexico on December 19, 2010 (United States Environmental Protection Agency). The bottom right photo is of the destruction that a Phillips 66 pipeline explosion in Paradis, Louisiana on February 9, 2017 (NOLA.)

The pictures above show destruction that pipeline explosions can cause. In Dixon, Illinois the explosion killed two people and critically injured two others. The West Virginia incident was caused by corrosion and malpractice of inspection. This incident in West Virginia demolished three homes and damaged 800 feet of interstate road. This tragedy may have been avoided by utilizing the appropriate pipeline repair practices. The explosion in Central Mexico was caused by illegal and non-compliant pipeline connections. This explosion killed 28 people and destroyed over 100 homes in the area. The bottom right photo is of the destruction that a Phillips 66 pipeline explosion caused in Paradis, Louisiana, killing one person. The cause of the explosion is still under investigation, but it has been reported that it happened during regular maintenance and that some part of the piping system failed.

## **Research**

Project research focused on determining what components a standard operating procedure should have that would lead to reaching a zero percent incident rate while utilizing in-process welding to make money. Having a zero percent incident rate is imperative for keeping contractors competitive for winning and retaining new work. On the job casualties and environmental incidents can negatively impact a contractor's ability to make money and gain new work.

Interviews were conducted with several individuals that have direct working knowledge of in-process welding. The goal of this research was to establish what laws, regulations and best practices should be followed to create a checklist for in-process welding safely.

For a contractor to start working on in-process welding as a viable procedure, it was essential to examine the context and environment by examining laws and regulations, and then narrowing the focus by talking to industry professionals. The research was analyzed to form an in-process welding checklist, so field supervision could have a simple, action-orientated checklist that could help save lives and money. When in-process welding takes place, it requires various crafts and multiple contractors.

## **Research Method**

Because many professionals are working in the trades with direct knowledge of in-process welding, the best way to solicit information from them was to use face-to-face interviews. A mixture of professionals was selected from various roles in the trades, including certified welding inspectors,

superintendents, and welders. It was important to include many trades in this process because the different point of views were essential to better understanding the environment and the risks.

The following interview questions were used to gather the data needed for the in-process welding SOP.

#### Interview Questions

1. What is your professional title and how many years have you been in that line of work?
2. What codes are related explicitly to in-process welding?
3. Are there any welding best practices that should be added to a Standard Operating Procedure for in-process welding?
4. What should be done by before an in-process weld?
5. What should be done during an in-process weld?
6. What should be done after an in-process weld?
7. Do you have any lessons learned from previous in-process welding? If so, please explain one or two of them.
8. What are the most likely incidents to happen during in-process welding?

The research data gathered was used to create a functioning SOP that would serve as a checklist to follow before engaging in in-process welding. Some local variables such as inclement weather were left out of the SOP so that this document could be used elsewhere.

This checklist required information from field personnel as well as various academic works and governmental agencies. The databases and publications from these works were used to elaborate on the findings of the gathered research.

#### **Literature Review**

The American Petroleum Institute (API) is a trade association that supports the natural gas and oil industry by conducting and publishing research as well as influencing public policy. Their mission is to “promote safety across the industry globally and to influence public policy in support of a strong, viable U.S. oil and natural gas industry” (API, 2018). Their research can offer insight into discovering some of the industry’s best practices. API standard 1104 is the Standard for Welding Pipelines and Related Facilities (API,1999).

The API standard 1104 has a section specifically for in-process welding. This section offers insight and best practices for welding on live, pressurized piping systems that have been used for petroleum-based products. This section offers information for establishing processes that can help contractors make safe and legal in-process welds (API,1999).

## Welding Procedure Specification

For a welder to know the details of their scheduled welding scope, they must consult a Welding Procedure Specifications (WPS), a document that includes variables and requirements for welders to follow when making actual production welds. This document defines specifics for each type of weld. A welder’s qualification to use a WPS must be stored in a Procedure Qualification Record (PQR)

### Procedure Qualification Record

The PQR is where a welder’s test for a specific WPS is recorded. This document shows the material and other variables that were used during weld testing (Exhibit 4). This document must meet ASME Requirements for in-process welding. These are stored as proof that a welder has taken the appropriate steps to be able to weld in the field. This document is vital for documenting legal requirements, and it must be completed in-house by each company using them.

	<b>CONSTRUCTION COMPANY</b>	
<b>Procedure Qualification Record In-Process Welding</b>	Revision No <b>1</b>	SP No. <b>IPW</b>
	Revision Date: <b>10/10/18</b>	Form No. IPW
Welder Number: _____		
<b>Part I: To be completed by the JBH CWI</b>		
<b>A. Code Edition and Addenda:</b>		
<input type="checkbox"/>	ASME Section IX Edition: _____	Addenda: _____
<input type="checkbox"/>	AWS D1.1: Edition: _____	Addenda: _____
<input type="checkbox"/>	Other Applicable Documents: _____	
<b>B. Base Metal:</b>		
1.	Material Spec., Type & Grade: _____	to _____
2.	ASME P-No. and Group: _____	to _____
3.	Carbon Equivalent: _____	to _____
4.	Thickness of Weld Test Coupons: _____	to _____
5.	Diameter (if applicable): _____	to _____
6.	Water Flow _____	to _____
7.	Other Requirements: _____	

**C. Weld Filler Metal:**

- 1. ASME Specification: Root: \_\_\_\_\_ Fill: \_\_\_\_\_
- 2. AWS Classification: Root: \_\_\_\_\_ Fill: \_\_\_\_\_
- 3. ASME Weld Metal Analysis A No. Root: \_\_\_\_\_ Fill: \_\_\_\_\_
- 4. ASME Filler Metal Group F No: Root: \_\_\_\_\_ Fill: \_\_\_\_\_
- 5. Filler Metal Size Root: \_\_\_\_\_ Fill: \_\_\_\_\_

**D. Welding Process and Welding Parameters:**

- 1. Process: \_\_\_\_\_ Root: \_\_\_\_\_ # of Passes Over Root: \_\_\_\_\_ Fill: \_\_\_\_\_
- 2. Spool Position: \_\_\_\_\_
- 3. Water Pressure \_\_\_\_\_  
# of Passes: \_\_\_\_\_
- O<sup>2</sup> Content of Purge Gas Before Welding: \_\_\_\_\_ CO<sup>2</sup>
- 4. Preheat Minimum: \_\_\_\_\_ °F
- 5. Interpass Temperature: \_\_\_\_\_ °F Maximum (achieve for at least one pass)
- 6. Electrical Characteristics: (List by Welding Process)  
 Process \_\_\_\_\_ Current: \_\_\_\_\_ Polarity: \_\_\_\_\_ Transfer Mode: \_\_\_\_\_  
 Process \_\_\_\_\_ Current: \_\_\_\_\_ Polarity: \_\_\_\_\_ Transfer Mode: \_\_\_\_\_

- 7. Bead Placement Technique: \_\_\_\_\_
- 8. Multipass Technique: \_\_\_\_\_
- 9. Welding Position to be Tested: \_\_\_\_\_  
Type of Progression: \_\_\_\_\_
- 10. Amperage, Voltage and Travel Speed (per Welding Process and Filler Wire Diameter)

Process	Pass	Filler Metal Diameter	AMPS	Volts	Speed	Pressure	

11. Joint Design to Use: (NORMAL JOINT IN-PROCESS DEFAULT)

12. Post Weld Heat Treatment: (PWHT)  Yes  No

Temperature: \_\_\_\_\_ °F

Time at Temperature: \_\_\_\_\_ Hr

PWHT Procedure To Be Used: \_\_\_\_\_ Rev: \_\_\_\_\_

**E. Tests To Be Performed:**

1. Mechanical Test:

a. Tensile Tests (QW-150)  Yes  No

Number of Specimens: \_\_\_\_\_ Type: \_\_\_\_\_ Per Fig: \_\_\_\_\_

Locations of Specimens: \_\_\_\_\_

Acceptance Per: \_\_\_\_\_ psi

- b. Bend Tests (QW-160)  Yes  No

Number of Sides Bend Specimens: \_\_\_\_\_ Per Fig: \_\_\_\_\_

Number of Face and Root Bend Specimens: \_\_\_\_\_ Per Fig: \_\_\_\_\_

Locations of Specimens: \_\_\_\_\_

Acceptance Per: \_\_\_\_\_

- c. Toughness Tests (QW-170)

(Carpy V-Notch):  Yes  No

Test Temperature: \_\_\_\_\_

Number of Specimens: \_\_\_\_\_ Base Metal: \_\_\_\_\_ Weld Metal: \_\_\_\_\_ HAZ

Locations of Specimens: \_\_\_\_\_

Per Figure: \_\_\_\_\_

Minimum Acceptance: \_\_\_\_\_ Ft/Lbs \_\_\_\_\_ Mils Lateral Expansion

2. Metallographic Tests

- a. Macro Etch Section Tests:  Yes  No

Number of Specimens: \_\_\_\_\_

Inspected at: \_\_\_\_\_ % Magnification

Acceptance Per: \_\_\_\_\_

- b. Hardness Transverse Tests:  Yes  No

Number of Specimens: \_\_\_\_\_

- c. Magnetic Verification of Delta-Ferrite Tests:

Yes  No

Number of Specimens: \_\_\_\_\_

In-Process – 50% Weld Level

Completion

Acceptance Per: \_\_\_\_\_

- d. Sensitization Tests:  Yes  No

Number of Specimens: \_\_\_\_\_

Acceptance Per: \_\_\_\_\_

3. Nondestructive Test:  Yes  No

Radiographic: \_\_\_\_\_

Acceptance Per: \_\_\_\_\_

4. Other Required Tests: \_\_\_\_\_

\_\_\_\_\_  
JBH AWS CWI

\_\_\_\_\_  
Date

\_\_\_\_\_  
Seth Loosli PM

\_\_\_\_\_  
Date

<b>Part II: To be completed by the JBH AWS CWI</b>	
<b>A. Welder Assigned:</b>	_____
<b>B. Start of Welding Date:</b>	_____
<b>C. Test Facility:</b>	_____
<b>D. Pre-Test Inspection</b>	

*Exhibit 5*

To meet the requirements needed for a PQR that covers in-process welding, a specific welding test must be taken. In-process welding requires a specific welding test to manage heat-loss from moving liquids. When a live piping system has product flowing, the liquid can affect an in-progress weld by removing heat from the weld area too quickly. The removal of heat at an accelerated rate can cause a weld to crack or fail. To replicate this phenomenon in the field a particular type of test spool must be used (Exhibit 6).



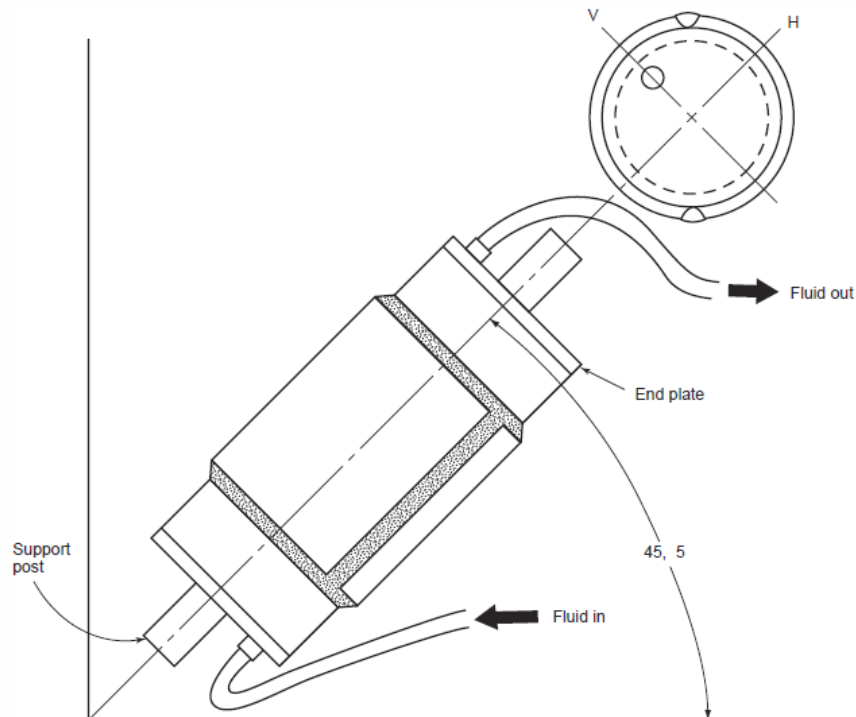

Note: This test position qualifies the procedure for all positions. Tests may be performed in other positions which will qualify the procedure for that position only.

*Exhibit 6.* This is an example of a test spool for welder qualifications on in-process systems (API 1999).

The heat loss problem is replicated by setting up a test spool like the spool in Exhibit 5. The American Petroleum Institute recommends setting up a similar test spool with flowing water. This recommendation says using flowing water is adequate to address most heat loss issues experienced in the field, however other liquids can be used if the correct parameters are not being achieved with water in the test system (API,1999).

### **Weld Cracking**

Having duly qualified welders helps avoid two common issues when welding on pressurized piping systems. The first issue is the cracking of welds during or after welding. The next issue has to do with the welding rod penetrating the entire thickness of the piping system. The welding trade refers to this as burn-through.

Weld cracking is common during in-process welding because the moving of liquid takes heat away from the welding area at an increased rate. The hydrogen cracking of welds generally happens when the three variables listed below happen:

- Hydrogen is present in welding material
- Above threshold tensile strength to the piping system

- Applied welding material microstructure is crack susceptible.

To reduce the occurrence of hydrogen cracked welds, a welder must remove or mitigate the above-listed variables. To reduce hydrogen levels in welding material the WPS should include the use of an 18 series rod. The electrodes in this series are considered low hydrogen. Removing tension on a piping system can alleviate cracks. This can be achieved by making sure a piping system is level, plumb and supported according to engineering specifications.

To reduce the presence of crack susceptible microstructures, the welding machine heat output should be set as high as the material and specification allows it. Also, if the field situation is suitable for pre-heating and the temper bead method they should both be utilized (Exhibit 6).

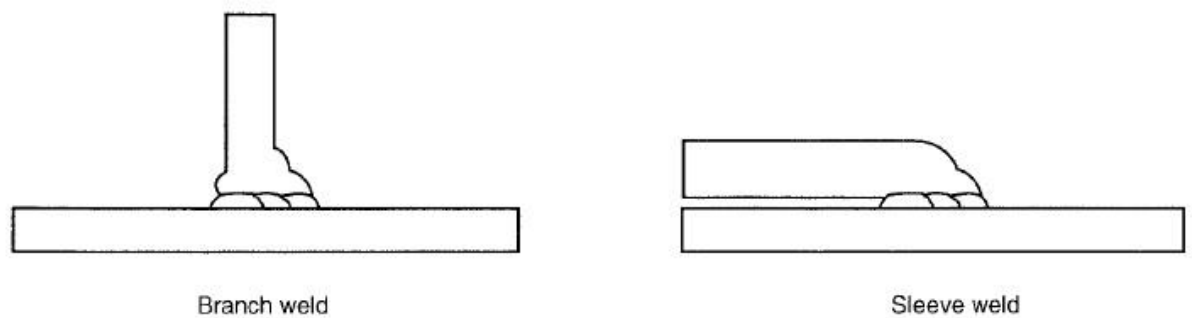

Notes:□

1. A layer of weld metal “buttering” is first deposited using stringer beads.□
2. Higher heat input levels are used for subsequent passes, which refine and temper the HAZ of the first layer.

*Exhibit 7.* The temper bead process reduces the prevalence of crack-susceptible microstructures

If the damaged piping material is too thin, then the upper ranges of acceptable heat output will be too dangerous. If the heat output is too low material cohesion may be reduced to a point where crack susceptible microstructures are prevalent. The solution for this is to utilize the tempering method mentioned above (API, 1999).

It is now known that speedier welds reduce instances of hydrogen cracked welds. Also, during the last 50 years, the composition of electrodes and steel pipe have changed to help reduce this problem. When conducting in-process repairs generally there are no breaks between the start and finish of welds (Exhibit 7). This is partially due to the lower heat input ranges required for initial weld passes. It is hypothesized that there is a reduction in hydrogen cracked welds because of the three following variables:

- Reduction in carbon content in materials
- Increased alloy percentages
- Piping materials being thicker and allowing more heat

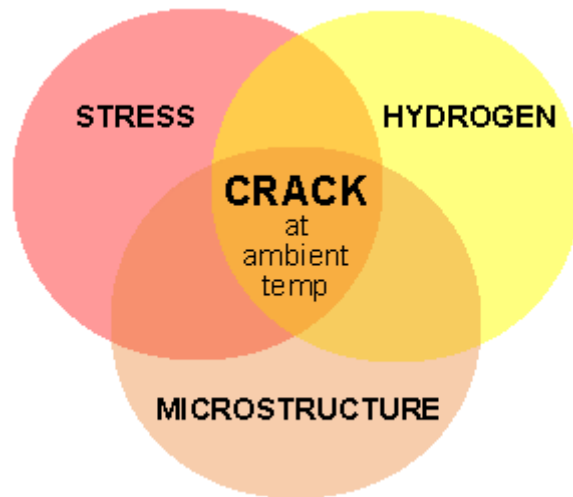

*Exhibit 8.* Cracking most often occurs when the weld zone returns to ambient temperature (TWI, 1999).

Another way to reduce the prevalence of disasters caused by hydrogen cracked welds is to do a thorough inspection after welding is completed. This means that the correct inspection procedures should be explicitly created for in-process welding (Exhibit, 8). Furthermore, the same inspection procedures should be used during welder qualification and field repairs to account for consistency. A significant concern with hydrogen cracking welds is they the effects can sometimes be time delayed. Time should be set aside for this time delay during the final inspection.

The American Welding Society (AWS) D1.1 code covers the storage of low hydrogen welding electrodes. The storage of low hydrogen welding materials is essential to follow (Exhibit 9). If this code is not followed the composition of the low hydrogen material can be compromised, and this can lead to welds that cracks. The AWS set up heat and humidity values to decrease the risk of adding additional hydrogen to a welding area. Furthermore, it is essential to follow this code because if the welding materials become contaminated the impurities are not visible to the naked eye. This leads to problems being discovered too late, and it adds the need for costly rework (AWS, 2005).

		<b>CONSTRUCTION COMPANY</b>	
		<b>In-Process Welding</b>	
<b>Weld Rod Oven Temperature Monitor Sheet In- Process Welding</b>		Revision No <b>2</b>	SP No. <b>SP 09.05</b>
		Revision Date <b>10-Oct-18</b>	Form No. <b>SP 09.05-F06</b>

Oven Location _____ Oven No _____ Temperature Req'd _____ °F							
Date	Temperature	Thermometer No.	BY	Date	Temperature	Thermometer No.	BY

Exhibit 9. Welding electrodes must be monitored to meet code and procedure standards

### Burn-through

As previously mentioned, an increase in heat input is one of the ways to combat the hydrogen induced cracking welds commonly associated with the in-process welding procedure. This technique does not come without its risks. Because in-process welding is often done on damaged piping systems, there is an increase in the chances that the welding electrode can penetrate the piping material. When this burn-through happens on pipes with an outside diameter of 2.375 inches or greater, it is considered a welding defect (Exhibit, 10). Moreover, during in-process welding, this can lead to a release of process or an explosion (API, 1999).

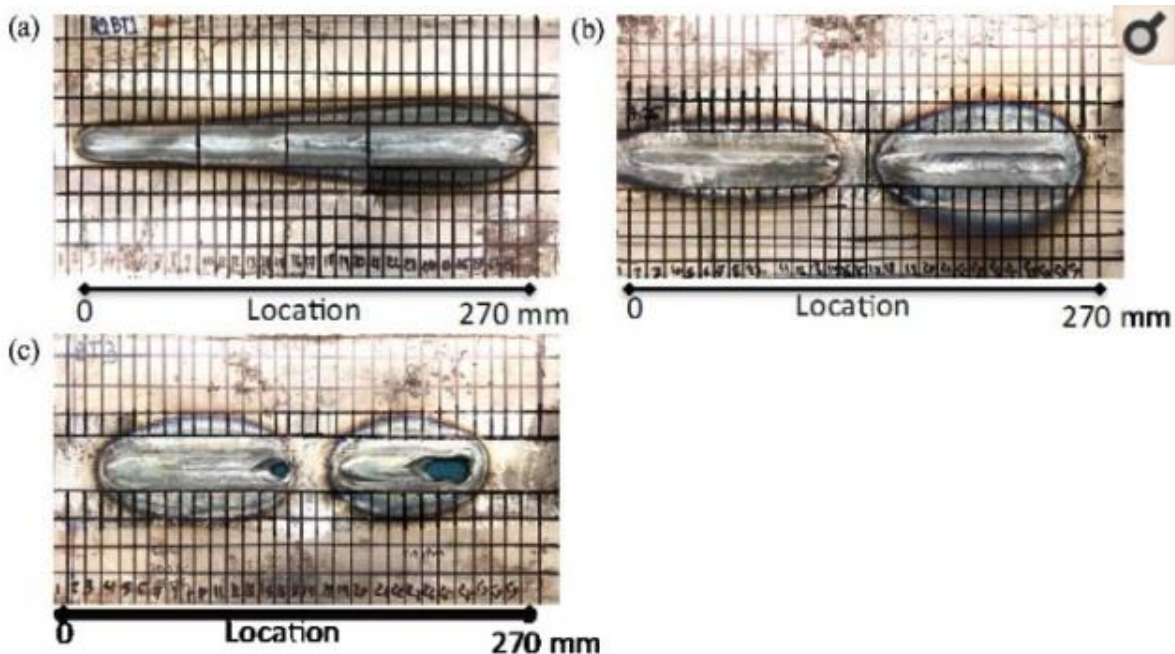

*Exhibit 10.* Weld coupons with different degrees of burn-through defect: (a) weld coupon No. 1; weld coupon No. 2; and (c) weld coupon No. 3. (NLM, 2018).

Welding burn-through is common in damaged piping areas. It is up to the welder to have the skills necessary so that burn-through does not turn into a catastrophic event that leads to the loss of life and damage to the environment. Another way to ensure the welder has done the job properly is to have an inspection plan. An inspection plan starts before welders start welding and ends after the welding is complete.

## **In-Process Welding in the Field**

### **Before**

In-Process welding takes several different crafts must prepare. Once this preparation is made it is time to begin the most immediate in-process welding procedures. It is recommended that the welding scope package is set-up through a document control process to keep track of who and when information is being accessed. Next, the field system should be field-verified against the WPS. At this time, the initial NDE requirements listed in the WPS should be executed. Once the piping system repair location has been through the NDE process, it should be labeled and recorded in the scope package.

### **During**

When the NDE comes back, and workers are mobilized to start the actual in-process welding the next phase can begin. It is recommended that if the NDE comes back within the acceptable parameters, it is reverified in the field. At this point in the process, the piping system operations team should have reduced the operating pressure of the piping system so that it can be welded. The actual live pressure should be checked, and then a heat loss test can be performed. This test should be performed in front of in-house and client Quality Assurance/Quality Control (QA/QC). These steps can help limit the chances for hydrogen cracking to occur.

The next steps should also be followed to reduce hydrogen cracking. All welding materials should be field verified to meet the piping system and WPS. This includes the repair sleeve material and welding electrodes. At this stage, it is recommended to check the welders for the correct WPQ. Once all materials and welders are verified a Hot Work Permit (HWP) can be signed, and in-house and client supervision can be notified that welding has started.

The last step is to verify heat-loss values to make sure they stay within parameters. This last step while the welding is taking place is designed to reduce the chance of a welder burning-through the piping system material. Thus, avoiding a potentially catastrophic incident that would be detrimental to the health safety of employees and the environment.

## **After**

After the welders have finished the QA/QC can visually inspection all the welds that were made. Additional NDE that is piping system specific will be carried out if all the welds have passed visual inspection. Because the lines are still live, the weld will need to pass an in-service welding test. This means the pressure will be turned up above normal operating pressure to make sure the weld will survive its regular activity. If the weld holds against the pressure, the in-process welding cycle is almost complete (Exhibit 11). The system can be returned to normal operating pressure, and the final signatures on the scope and hydrostatic testing packages can be done at this time. The hydrostatic test should include at least the date of the test, the piping system identifiers which includes which process fluid and the test pressure.

## **Conclusions**

This project has created a useable standard operating procedure that will help the client make money by allowing them to bid for in-process work and by helping them stay safe while conducting this work with the help of the project sponsor and those that participated in data collection. The standard operating procedure that was created includes steps that help employees follow the welding laws and regulations as well as industry best practices.

## **Recommendations**

The American Petroleum Institute cites that the first significant pipeline boom began in the 1920s. The process of repairing piping systems soon follow. The materials and processes have been updating since then. The piping system repair field is changing. In the future contractors might benefit from using newer methods and materials than what is cited in this project.

Because of the limitations of the project sponsor, none of the newer methods of piping system repair were included in this project. Another limitation of this project was that none of the participants were trained engineers. Further studies could expand research by including engineers.

Furthermore, it is recommended these newer processes and materials being used be researched for their effectiveness in extreme climates. Finding alternatives to in-process welding can give companies a chance to reduce the time that their employees are in harm's way. This can also help reduce the risk of industrial and environmental incidents occurring. Removing personnel and the environment from harm's way should always be at the foundation of a contractor doing dangerous work. This research project should be used as a stepping stone to figuring out how these accidents and incidents can be prevented in the future.

## References

National Center for Biotechnology Information. *The Detection of Burn-Through Weld Defects Using Noncontact Ultrasonics*. Retrieved from <http://www.ncbi.nlm.nih.gov/pmc/articles/PMC5793626/>

Ossai, C. I., Boswell, B., & Davies, I. J. (2015). Pipeline failures in corrosive environments – A conceptual analysis of trends and effects. *Engineering Failure Analysis*, 53, 36-58. doi:10.1016/j.engfailanal.2015.03.004 regulate the remaining population of unregulated rural hazardous liquid low stress pipelines, which was required by the Pipeline Inspection, Protection, Enforcement, and Safety (PIPES) Act of 2006;

U.S. department of transportation administrator, pipeline and hazardous materials safety administration cynthia quarterman, testifies before house energy and commerce subcommittee on energy and power - final.(2011,Jun16). FairDisclosureWire Retrieved <http://search.proquest.com.proxy.consortiumlibrary.org/docview/874356222?accountid=14473>

PHMSA | Pipeline and Hazardous Materials Safety Administration. *Pipeline Incident 20 Year Trends / PHMSA*. Retrieved from <http://www.phmsa.dot.gov/data-and-statistics/pipeline/pipeline-incident-20-year-trends>

Standard, A. P. I. (1999). 1104, Welding of pipelines and related facilities. American Petroleum Institute, 20.

Welding, A. S. M. E. (2004). brazing qualification, ASME boiler and pressure vessel code, Sec.

Welding, B. S. P. (2012). Qualify processes and operators according to ASME Boiler and Pressure Vessel Code: Section IX, ". *Welding and Brazing Qualifications*, 1, 00-2.

National Center for Biotechnology Information. *The Detection of Burn-Through Weld Defects Using Noncontact Ultrasonics*. Retrieved from <http://www.ncbi.nlm.nih.gov/pmc/articles/PMC5793626>





## Appendix A. Standard Operating Procedure

### In-Process Welding Checklist

#### 1. Before In-Process Welding

- Get a welding scope package (Follow Document Control Procedures).
- Verify the piping system against Welding Procedure Specification (WPS)
- Conduct initial Nondestructive Evaluation (NDE)
- Verify NDE location and label with welding scope package information.

#### 2. During In-Process Welding

- Verify initial NDE within acceptable parameters.
- Perform heat loss testing with client QA/QC present.
- Verify welding materials match WPS (Verify Low Hydrogen procedures have been followed)
- Verify repair materials match WPS for piping system.
- Sign-off on visual inspection of weep hole and mark on repair sleeve.
- Verify Welder Performance Qualification (WPQ) for piping system WPS.
- Verify piping system pressure is within acceptable parameters. Pressure: \_\_\_\_\_
- Verify the Hot Work Permit (HWP) signed by in-house and client safety. Time Signed: \_\_\_\_\_
- Update in-house and client supervision if ready to weld. Time Ready to Weld: \_\_\_\_\_
- Verify QA/QC monitoring heat loss values and verify authority to stop welding if it falls out of parameters.

#### 3. After In-Service Welding

- Visually inspect welds and call out 3<sup>rd</sup> party NDE if not on site.
- Verify the hydrostatic testing package complete with NDE.

- Verify external valves meet clearance requirements per WPS.
- Verify piping system pressure within parameters for hydrostatic testing.
- Verify QA/QC on site for the entire hydrostatic testing process.
- Receive final signatures on welding scope package and hydrostatic testing package

## Appendix B. Interviews

**Date:** 1/27/2018 **Time:** 3:00 PM **Facilitator:** Seth Loosli

Subject for Meeting

### In-Process Welding Introduction

Interviewee 1 has over a decade of welding in fabrication shops, pipelines and offshore platforms. Currently he runs his own company and works in Alaska and Idaho.

#### Codes Relating to In-Service Welding

API 1104-Appendix B - B.3 This code is important because it sets the standards on how welders can be qualified to weld on oil and or gas lines. ASME B313 is also pertinent because it covers some of the laws and regulations when doing new construction. B313 has firmer NDT (nondestructive testing) requirements in some cases.

#### Best Practices

A company should not place all the coding requirements on its QA/QC. Anyone working directly on a weld (welders, pipefitters, helpers) should use a welding checklist based on applicable codes for the type of welding being performed. This can help raise hazard awareness and reduce the need for rework.

#### Before, During and After Welding

Before live welding takes place the QC department should make sure all welding certifications are up to date and applicable to the type of live welding. Any special requirements should be documented and transmitted to team members and leadership. This information should also make it into the hands of the safety department

During welding there should be a dedicated team to monitor the operating conditions of the live pipe as well as monitoring the heat input from the actual welding.

After welding is complete the weld should be monitored visually at set intervals until an NDT team can test it to the clients and/or legal requirements

#### Lessons Learned

Companies choose live welding because it can save lots of money by reducing the impact of process not flowing. To keep in the spirit of this the work area must be cleaned and cleared out. Any valves or connections in the area must be inspected thoroughly. A minor leak can lead to a major safety shutdown that can cost a lot of money.

## Risks Associated with Welding

Because live welding takes place with moving liquid that is combustible or flammable heat input must be monitored to make sure a high-quality weld is being applied. Incorrect heat input can lead to the biggest two risks associated with live welding; failed welds and punch through where the welding causes open ruptures to the pipe. The second mention can lead to explosions or fire. If high pressure is applied to a previously damaged weld the piping could separate causing the piping to tear.

**Date:** 4/27/2018

**Time:** 3:30 PM

**Facilitator:** Seth Loosli

### **Subject for Meeting**

In-Service Welding

### **Introduction**

Interviewee 2 is a formally trained mechanical engineer from India. He is currently working as a piping superintendent for the largest turnaround company in the United States.

### **Codes Relating to In-Service Welding**

Find the ASME codes that pertain to in-service welding and general hot work.

### **Best Practices**

Review scope of work for special requirements and make sure the Welding Procedure Specification (WPS) matches what you are doing

### **Before, During and After Welding and Lessons Learned**

**Before:** Have field management schedule walks with QA/QC to verify if Nondestructive Evaluation (NDE) is needed. Make sure QA/QC is with the field crew if NDE procedures are needed.

**During:** Make sure the field crew, the client operator and QA/QC review the scope of work on site when welding begins. Also, verify the correct welding materials are staged properly (check for heat and moisture requirements)

**After:** After the weld is complete keep welding crew on stand by while operations returns line to normal operating pressures.

### **Risks Associated With Welding**

NDE can determine risky areas for burning through the original pipe material

**Date:** 4/07/2018

**Time:** 2:00 PM

**Facilitator:** Seth Loosli

### **Subject for Meeting**

In-Service Welding

#### **Introduction**

Interviewee 3 holds a CWI and has been inspecting in the field for 6 years.

#### **Codes Relating to In-Service Welding**

API1104 is the most important code relating to in-service welding. This is the code that dictates how welders are qualified to weld on in-service piping.

#### **Best Practices**

In-service welding in of itself is a best practice. Welding as is can reduce construction costs as well as lost production costs.

#### **Before, During and After Welding**

Pre weld inspection is a serious step that should not be skipped. The QC world has many tools that go beyond visually inspecting materials. Monitoring heat during a weld can save costly rework and reduce the risk for a process related explosion. After the weld the contractor doing the weld should conduct NDT as well as a third party. Depending on the contract, it might be beneficial for a contractor to spend extra money up front to make sure quality is high.

#### **Lessons Learned**

Procedures and experience look great on paper but, a persons health and morale should be looked at before doing this type of welding. Also, because these applications are so dangerous defects found in welds that are technically passable should be rejected and repaired.

### **Subject for Meeting**

In-Service Welding

#### **Introduction**

Interviewee 4 has held a CWI (Certified Welding Inspector) for over six years. Currently he is the QA/QC manager for a large, multi-year project at Intel in Chandler, Arizona.

### **Codes Relating to In-service Welding**

There are a number of codes that need to be reviewed and referenced by anyone engaging in live welding. Live welding also relates to piping that has been removed from serviced. Because of hazards Any pipe that has ever had process run through it must be treated as a live system. Look at codes ASME B31-3, B31.1 Section IX and API 570

### **Best Practices**

Finding best practices for welding on live process really depends on the jurisdiction and severity of services. For example, DOT (Department of Transportation) has much more strict guidelines for welding on DOT regulated services. Also, different chemical flows warrant different best practices.

### **Before, During and After Welding**

Before doing live welding all process piping being worked on and in the work area need to be verified. All the welders and other hands on employees must be qualified for the type of welding. Furthermore, it is important to study the procedures and safety protocols before work starts.

The most dangerous part of live welding occurs when the welding begins. While work is being performed a trained professional must monitor for abnormal conditions and performance standards laid out by the agreed protocol.

After the welding completed the weld must be physical verified and visually examined for compliance to national welding standards. Once a visual test is completed, depending on the variances in contracts, NDT (non-destructive testing) can be completed at this time. It is highly recommended that NDT is verified before returning the service to full operating pressure.

### **Lessons Learned**

Always verify with operations that the flow rate of the fluid is in acceptable parameters. The heat input can be monitored in real time while the weld is happening. If the flow rate is too high the residual heat input can be reduced; this can lead to welds cracking. If the flow rate is too low, residual heat can increase to an unsafe level which can lead to the process fluid combusting.

### **Risks**

Many risks are associated with live welding. The major risks to look out for are fires, explosions, toxic fumes, burns, falls and weld failures.

**Date:** 4/28/2018

**Time:** 9:00 AM

**Facilitator:** Seth Loosli

### **In Attendance**

Certified Welding Inspector (CWI)

### **Subject for Meeting**

In-Service Welding

#### **Introduction**

Interviewee 5 is a CWI who is currently working on various pipeline projects on the east coast.

#### **Codes Relating to In-Service Welding**

ASME, ASTM, EN 288, EN 473

#### **Best Practices**

When testing heat and flow rates check 24 hours before welding begins and in real time for the duration of the welding.

#### **Before, During and After Welding and Lessons Learned**

Validate all welders are certified for the Weld Procedure Specifications (WPS) being used. Also, verify welding materials match WPS requirements. Make sure all welding materials are stored correctly and separately. Make sure all Nondestructive Testing (NDT) has been signed off by the client, the welders and QA/QC

#### **Risks Associated With Welding**

If heat dissipation is too high there is a risk for the welds to crack which could lead to an explosion or process event.

**Date:** 5/27/2018

**Time:** 11:00 AM

**Facilitator:** Seth Loosli

### **Subject for Meeting**

In-Service Welding

#### **Introduction**

Interviewee 6 is a mechanical consultant with more than 20 years piping experience.

#### **Codes Relating to In-Service Welding**

N/A

#### **Best Practices**

Have pre-job meetings with client and field crews, and QA/QC. Discuss emergency response plan and risks associated with this type of welding.

### **Before, During and After Welding and Lessons Learned**

Do multiple heat loss tests to set baseline. Pressure must be verified and signed by all parties involved. Keep welding certificates and welding plan documents on site at all times. Keep communication channels open in case pressures change.

#### **Risks Associated With Welding**

N/A

**Date:** 7/6/2018

**Time:** 5:30 AM

**Facilitator:** Seth Loosli

#### **Subject for Meeting**

In-Service Welding

#### **Introduction**

Interviewee 7 is a Certified Welding Inspector (CWI)

#### **Codes Relating to In-Service Welding**

ASME B31-3, B31.1 and API 570, ASTM codes and some EN

### **Before, During and After Welding and Lessons Learned**

Verify all welding certificates. If welders are close to expiration for a particular procedure retest them before doing in-process work. Create a cohesive separate document with all QA/QC actions; make sure this document is in chronological order. After all testing is completed get all stakeholders to sign off job complete forms and make sure document control receives the originals ASAP.

#### **Risks Associated With Welding**

Make sure correct welding material is used.

**Date:** 4/27/2018

**Time:** 11:00 AM

**Facilitator:** Seth Loosli

### **Subject for Meeting**

In-Service Welding

### **Introduction**

Interviewee 8 is currently working as a project manager on a multi-billion dollar semiconductor project. His team works specifically with process piping.

### **Codes Relating to In-Service Welding**

ASME B31-3, B31.1 and API 570 are the two most common codes that the project management department come across.

### **Best Practices**

When dealing with corrosion or erosion it is very important to know the extent of damage. Paying for extra testing up front can save lives and reduce the risk of a process related event

### **Before, During and After Welding and Lessons Learned**

Plan, plan, plan and do some more planning. A heightened level of safety and permitting processes should be implemented. In-service welding is arguably the most dangerous welding there is. All general welding codes should be reviewed. Furthermore, the welding procedures for the type of welding should be made readily available. These welding procedures should be shared with all trades working in the area. Sometimes it is helpful to have fresh eyes watching how things work.

### **Risks Associated With Welding**

Every live welding plan has built in hold points. Even if you have an experienced crew, it is imperative to observe these hold points

**Date:** 7/1/2018

**Time:** 11:00 AM

**Facilitator:** Seth Loosli

### **Subject for Meeting**



## In-Service Welding

### **Introduction**

Interviewee 9 has 10 years piping experience.

### **Codes Relating to In-Service Welding**

ASME and API codes.

### **Best Practices**

If inclement weather is expected make sure to prepare the welding area and make sure the procedure can be done properly in conditions.

### **Before, During and After Welding and Lessons Learned**

Verify procedures and certifications. Arrange nondestructive testing. Check welding materials and consumables. Document all welding materials for close out package. Verify lines and scope with client and contractor. Communicate with client operators to verify pressure before welding.

Appendix C. Field Welding

	<b>CONSTRUCTION COMPANY</b> <i>In-Process Welding Procedure</i>	
<b>Field Documentation</b>	Revision No <b>0</b>	Scope Date:
	Revision Date: <b>24 Oct 18</b>	Form No. <b>IP-WP-FD-01</b>

<b>Field Installation of piping</b>						
<b>Approval Change History</b>						
Issue	Description	Approval				
		Date	Quality Control Manager	Project Manager	Client	
<b>0</b>	<b>Issued for Approval</b>					
<b>1</b>	<b>Revised to Incorporate Client Comments</b>					

Inspection Codes Key      H= Hold Point W= Witness M= Monitor	V= Visual Inspection D= Dimension Inspection R= Review & Approve Docs	Responsibility SC=Subcontractor                      ST= Store man WF= Workshop Foreman E/I=Inspection/Expeditor TR= Tradesman QC= Quality Inspector
--	---	---

1.0	<b>Approvals before Install</b>				QA/QC Management	H	R	
1.1	Welding Procedure Specifications (WPS)	Project Quality Plan	ASME Section IX	Approved WPS/PQR	WE/QC	H	M/R	
1.2	Qualify welders to approved WPS		ASME Section IX	WQR	WE/QC	H	R	
1.3	Prepare WPS and Approve Welder Registers		ASME Section IX	Registers	WE/QC	H	R	
1.4	Review Subcontractors ITP's		ASME/Spec Contract	ITP		H	R	Not required if this ITP pre-approved is used.

<b>2.0</b>	<b>Field Test Inspection</b>							
2.1	Approved WPS available in Field	Project Quality Plan	ASME /Code	Current Revision Documents	WF/QC	M	M	
2.2	Check material for item, type, material, size, rating & unique number.		ASME / Spec	AFU Dwg	WF/EX	V/M	M	
2.3	Check Weld Preparations		WPS/ ASME	AFU Dwg	WF/QC	V/M	M	
2.4	Calculate NDT % Requirements on Piping-Confirm Piping		Spec/ Code	EC-F-054	WF/QC	V/D	R	Nominate on Subcontractors NDT% Form
2.5	Check Welding Consumables		WPS	WPS	QC	V/M	M	
2.6	Check fit-up, configuration, dimension and orientation.		WPS	AFU Drawing	QC	V/M	M	
2.7	Check for spool and sub spool identification		AFU Drawing	AFU Drawing	QC	V/M	M	
2.8	Check Welder Qualification		Welder Continuity	WQR/ Continuity	QCR	R	M	
2.9	Check Welding parameters (if applicable)		WPS	WPS	QCR	M	M	
2.10	Check weld marking (welder's ID, date and consumable)		Spec/Contract	Weld Maps/Weld Tracker	QCR	V/M	M	
2.11	Check weld root and hot pass (If applicable)			WPS	QCR	V/M	M	
2.12	Check removal of slag, spatter, scale and flux. (if applicable)		ASME/Spec	ITP/ Checklist	QC	V/M	M	
2.13	Check Completed Weld		ASME/Spec	Visual Inspection	QC	V/M	M	
2.14	Record welding traceability information		ASME Div.	Not Report	QC	V/M	M	

<b>3.0</b>	<b>Inspection and Test</b>							
3.1	All Welds 100% Visual Examination	Project Quality Plan	Spec- Section	This ITP	QC	V	M	Verify & Accept by signing Section 4.1 of this ITP
3.2	NDE per Spec-Section XXXX a). 5% RT Normal Fluid Service		Engineering Drawings/Spec Code ASME	NDE Tracker	QC	H	W	
3.3	Pipework marking, and identification correct		Spec Section	Punch List	QC	M	M	
3.4	Mark up drawing and as-built as necessary		Spec- Section	Engineering Drawings marked in red pen.	QC	R		
3.5	Verify NDT % has been completed			NDT Reports	WF/QC	H	R	

3 . 6	Preparation for assembly any damage to the gasket seating surface which would prevent gasket seating shall be repaired, or the flange shall be replaced.		ASME B31.3 Para 335.2.1					
3 . 7	Bolting Torque (a) In assembling flanged joints, the gasket shall be uniformly compressed to the proper design loading. (b) Special care shall be used in assembling flanged joints in which the flanges have widely differing mechanical properties tighten to a predetermined torque is recommended.	Project Quality Plan	ASME B31.3 Para 335.2.2	Reports/ checklists	WE/EX	H/R	R	
3 . 8	Bolt Length should extend entirely through their nuts. Any which fail to do so are considered acceptably engaged if the lack of complete engagement is not more than one thread.		ASME B31.3 Para 325.2.3	Checklist	EX	M	M	Every item shall be marked and listed on the Delivery Docket.
3 . 9	Tubing Joints The sealing surface of the flare shall be examined for imperfections before assembly, and any flare is having imperfections shall be rejected.		ASME B31.3 Para 335.4.1	Checklist	EX	M	M/R	
3 . 1 0	Flareless and Compression Tubing Joints Where the manufacturer's instructions call for a specified number of turns of the nut, these shall be counted from the point at which the nut becomes finger tight.		ASME B31.3 Para 335.4.2	Go or No-Go Gauge Report	EX	M	M	
3 . 1 1	Preparation for Leak Testing		Contract Spec			R	R	

4.0	All joints, including welds and bonds, are to be left uninsulated and exposed for examination during leak testing, except		ASME B31.3 Para 345.3.1	Checklist		H		
-----	---	--	----------------------------	-----------	--	---	--	--

	that joints previously tested by this Code may be insulated or covered. All joints may be primed and painted before leak testing unless a sensitive leak test is required (Para 345.8)							
4.1	Temporary Supports Piping designed for vapor or gas shall be provided with additional temporary supports, if necessary to support the weight of the test liquid.	Project Quality Plan	ASME B31.3 Para 345.3.2	Check list	WE/QC	H	R/H	Client Rep to review completed MDR at source (MEA or Subcontractor facility) covering SOW
4.2	Does the system receive a Hydrostatic Test?		ASME B31.3 Para 345.1	Checklist				
4.3	Verify test fluid shall be water unless this is a possibility of freezing or to adverse effects of water on the piping or the process.		ASME B31.3 Para 345.4.1	Checklist				
4.4	Verify the test pressure is 1.5 times the design pressure?		ASME B31.3 Para 345.3.1	Checklist		H		
4.5	Verify Piping subassemblies may be tested separately or as assembled piping, Verify Flanged Joints at which a blank is inserted to isolate other equipment during a test need not be tested. Verify closure welds need not be leak tested provided the weld be examined in-process by Para 344.7 and passes with 100% radiographic examination by Para 344.5 or 100% ultrasonic examination by Para 344.6		ASME B31.3 Para 345.2.3	Checklist		H		
4.6	Verify that piping that is subject to external pressure shall be tested at an internal gauge pressure 1.5 times the external differential pressure, but not less than (15psig)		ASME B31.3 Para 345.2.4	Checklist		H		
4.7	Verify that the piping is disconnected from the equipment with either blinds or other means of isolation during the test.		ASME B31.3 Para 345.2.4	Checklist		H		
4.8	Verify that the piping is disconnected from the equipment with either blinds or other means of isolation during the test.		ASME B31.3 Para 345.2.7	Checklist		H		
4.9	Hydrostatic Testing Per ASME B31.3							

4.10	Verify the piping system pressure is within parameters included in the WPS and hydro test package			Checklist		H		
4.11	Verify a pressure relief device shall be provided, having a set pressure not higher than the test pressure plus the lesser of 50 psig or 10% of the test pressure.		ASME B31.3 Para 345.5.2	Checklist		H		
4.12	Verify that the test pressure shall be 110% of the design pressure		ASME B31.3 Para 345.5.4	Checklist	H			
4.13	Verify that procedure is used to bring up the system gradually to 25psig and is attained at which time a preliminary test of all joints in the system shall be examined. After that which the system shall be brought to full pressure and held a minimum of 10 minutes.		ASME B31.3 Para 345.5.5	Checklist/ Hydrostatic Test Procedure	H			
4.14	Test records shall include as a minimum (a) date of test, (b) identification of piping system tested, (c) test fluid, (d) test pressure, (e) certification of results by the examiner.		ASME B31.3 Para 345.2.7	Test Report				